

H
G
F
E
D
C
B
A

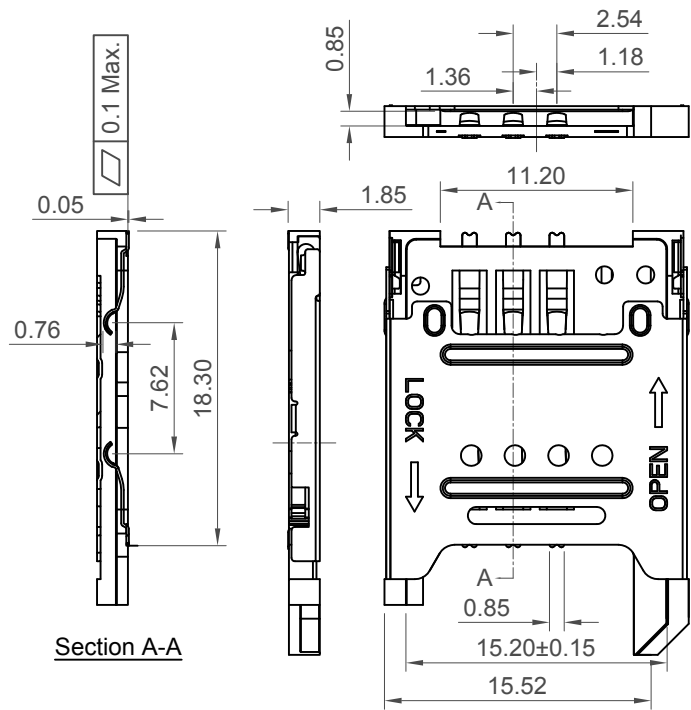

Section A-A

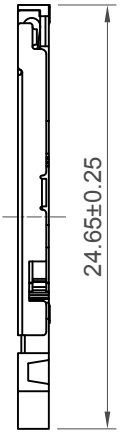

- C1---->VCC
- C2---->RST
- C3---->CLK
- C5---->GND
- C6---->Vpp
- C7---->I/O

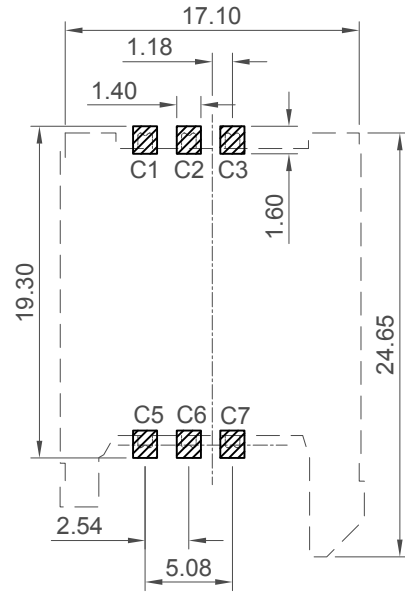

Recommended PCB Layout
General Tolerance ± 0.05

as viewed from component side
 Solder Area Component Outline

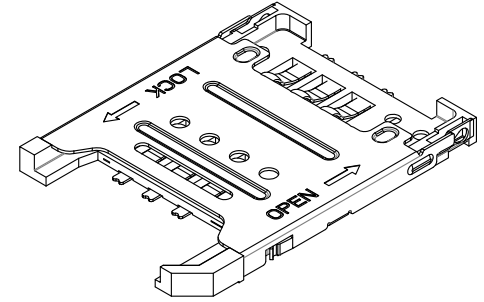

Specification 规格:

Material 物料规格:
 Plastic Housing 塑胶外壳: Hi-Temp Thermoplastic UL94V-0, E106764 (E130i), Black 高温塑胶, 黑色
 Contact Terminal 接触端子: Phosphor Bronze 磷青铜
 Metallic Shell & Hinge 金属外壳及铰链: Stainless Steel - SUS304
Plating 电镀规格:
 Contact Terminal plating 接触端子部分电镀:
 Under-plating 底层电镀: 50 μ m Nickel 镀镍 50 μ m
 Contact Area 接触部分: 3 μ m Gold 镀金 3 μ m
 Soldering Area 焊接部分: Gold Flash 镀金
Electrical 电气规格:
 Voltage Rating 电压额定值: 50VAC (R.M.S.) Max.
 Current Rating 电流额定值: 1A AC/DC
 Operating Temperature 工作温度: -40°C to +85°C
 Contact Resistance 接触电阻值: 50 m Ω typ., 100 m Ω max.
 Insulating Resistance 绝缘电阻值: 1000 M Ω Min. (Apply 施加 500VDC)
 Dielectric Withstanding Voltage 耐电压: Withstand 500 V AC for 1 minute 能承受 500 V AC 1 分钟
Mechanical 机械性规格:
 Durability 耐久性: 5,000 cycles 5,000 次插拔

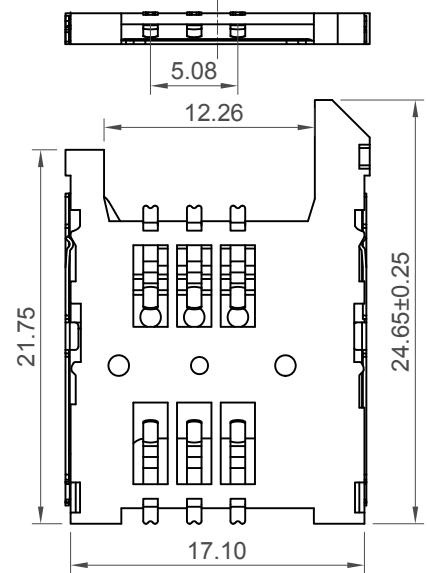

Ordering Grid

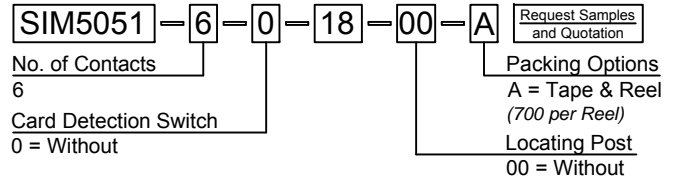

Part Number SIM5051		Product Description SIM Card Connector	
Drawing Date 4th October 2009		Hinged Type, 6 Pin, SMT, 1.85mm Profile	
By	AJO	Tolerances (Except as Noted)	Units:
Detail	SIM5051 F PCN	Length X.X \pm 0.25	Metric (mm)
Revision	F	Angle X.XX \pm 0.15	$X^\circ \pm 1^\circ$
Date	08/12/14	X.XXX \pm 0.050	X.XX' \pm 0.5"
		X.XXX' \pm 0.25"	

GCT
Global Connector Technology
www.gct.co

Not to Scale Drawn By SA Sheet No. 1/2

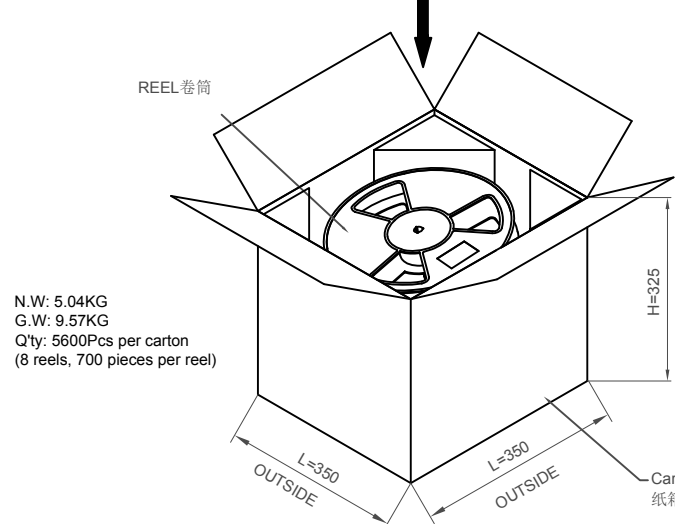
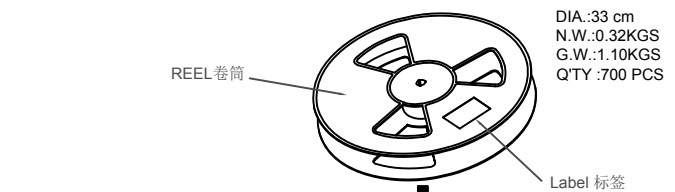
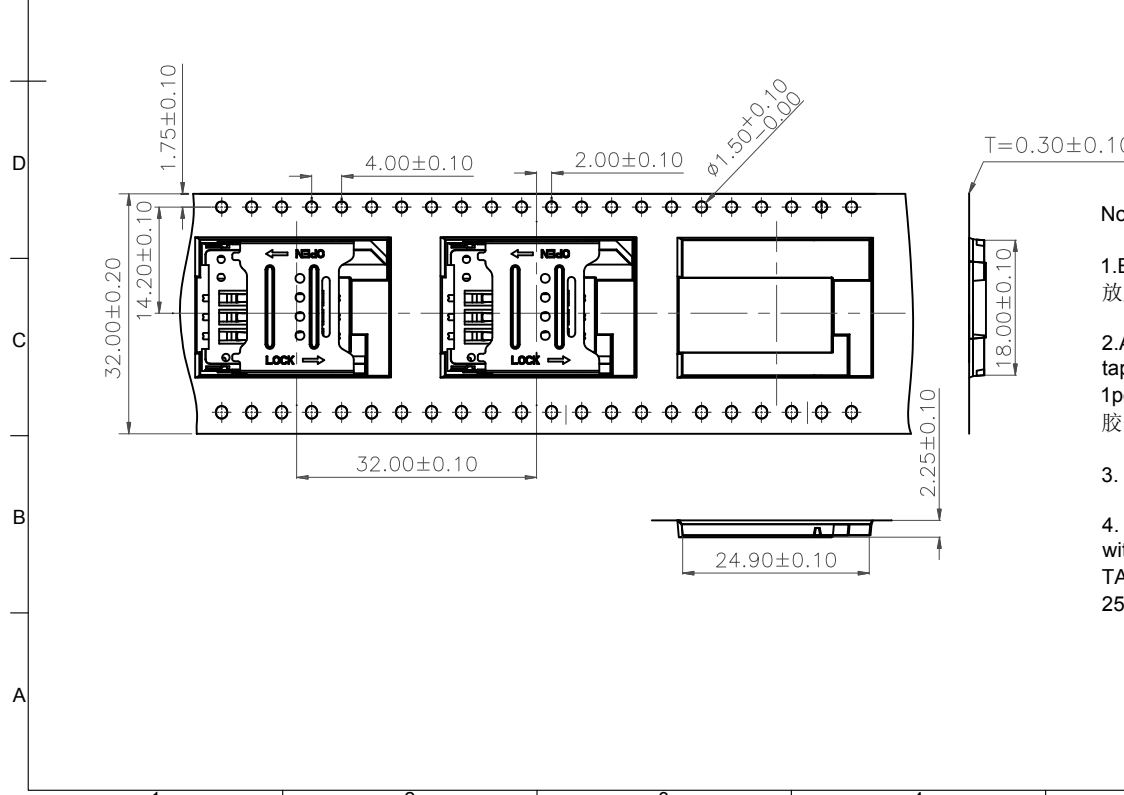
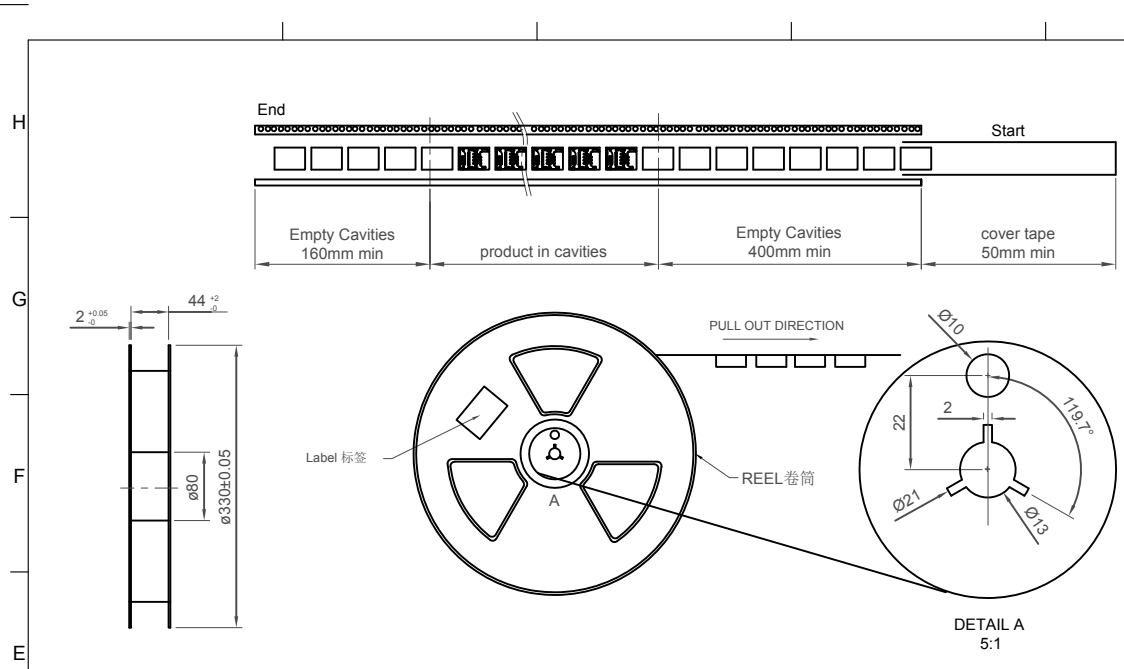

Notes注意:

1. Each cavity will hold 1pc. Placement methods are shown in the diagrams. 每穴放置1pc产品, 放置方式如图所示
2. After the packing machine filled the REEL, tangle the REEL one more loop with protection tape, stick adhesive tape on the four quadrants of the REEL, to avoid out-spreading. Stick 1pc. of label on each REEL. 包装机包好后,再缠上一圈电周波,在REEL的四个登峰造极点贴上胶带,以防止REEL张开,每REEL贴1PC标签
3. Method of Packing is Hot-Melting. 包装方式是热熔式
4. The peel-off force between the COVER TAPE & CARRY TAPE is: 0.1N-0.7N (variation within 0.3N). Peel-off angle:165-175 degree; Speed of peel-off: 250mm-300mm/min. COVER TAPE与CARRY TAPE剥离力:0.1N-0.7N (跳动量在0.3N以内)剥离角度:165-175度; 剥离速度: 250mm-300mm/分钟

Part Number SIM5051		Product Description SIM Card Connector Hinged Type, 6 Pin, SMT, 1.85mm Profile	
Drawing Date 4th October 2009			
By AJO	Tolerances (Except as Noted) Length Angle	Units: Metric (mm)	
Detail SIM5051 F PCN			
Revision F			
Date 08/12/14			

GCT
Global Connector Technology
www.gct.co

Not to Scale	Drawn By SA	Sheet No. 2/2
--------------	----------------	------------------