

## Main Feature

1. 92/8 gold silver alloy on silver palladium contact type is suitable for low level switching application.
2. Small size and light weight can provide high density Board mounting.
3. 2.54mm Terminal Pitch.
4. Low Coil Power Consumption of GS-T Type and high Coil Power Consumption of GS-D type are available to meet user's selection.
5. Employment of suitable plastic materials to be applied to high temperature and various chemical solution.
6. Plastic epoxy resin sealed type for washing procedure.

## Contact Rating

Load Type	GS (D)	GS (L)	GS (T)
Rated Load (Resistive)	1A 120VAC	1A 120VAC	1A 120VAC
	2A 24VDC	2A 24VDC	2A 24VDC
Rated Carrying Current	2A	2A	2A
Max. Allowable Voltage	AC 120V	AC 120V	AC 120V
	DC 24V	DC 24V	DC 24V
Max. Allowable Current	2A	2A	2A
Max. Allowable Power Force	120VA	120VA	120VA
	48W	48W	48W
Min. Switching Load	DC 1V, 1mA	DC 1V, 1mA	DC 1V, 1mA
Contact Material	Ag Alloy	Ag Alloy	Ag Alloy
Contact Form	DPDT	DPDT	DPDT

## Application

Telecommunication, domestic appliances, office machine, audio equipment, Remote Control, etc

## Performance (at Initial Value)

- Contact Resistance ..... 100mΩ Max. @100mA, 6VDC
- Operate Time..... GS-D 6 mSec. Max.  
GS-T 8 mSec. Max
- Release Time ..... 4 mSec. Max.
- Dielectric Strength :  
Between Coil & Contact ..... 1,000VAC at 50/60 Hz for one minute.  
Between Contacts ..... 500VAC at 50/60 Hz for one minute.
- Surge Strength ..... 1,500V (between coil & contact 1.2x50μSec.)
- Insulation Resistance ..... 100 MegaΩ Min. at 500VDC.
- Max. On/Off Switching :  
Electrical..... 30 Cycles per Minute.  
Mechanical 300 Cycles per Minute.

- Temperature Range .....-30~80°C
- Humidity Range .....45~85% RH.
- Coil Temperature Rise .....25°C Max. (D Type)  
20°C Max. (T Type)
- Vibration:  
Endurance..... 10 to 55 Hz dual amplitude width 1.5mm.  
Error Operation ..... 10 to 55 Hz dual amplitude width 1.5mm.
- Shock:  
Endurance .....1,000 m/S<sup>2</sup> .  
Error Operation ..... 100 m/S<sup>2</sup> .
- Life Expectancy:  
Mechanical .....10<sup>7</sup> Operations at No Load condition.  
Electrical .....10<sup>5</sup> Operations at Rated Resistive Load.
- Weight.....About 4.8 g.

## Safety Standard & Its File Number

- UL & C-UL.....E141060
- TÜV .....R9352326
- CQC.....06001015414

## Coil Specification (at 20°C)

Coil Sensitivity	Nominal Voltage (VDC)	Nominal Current (mA)	Coil Resistance ( $\Omega \pm 10\%$ )	Power Consumption (W)	Pull-In Voltage (VDC)	Drop-Out Voltage (VDC)	Maximum Allowable Voltage (VDC)
GS - D	3	120	25	Abt. 0.36	75% Maximum	10% Minimum	150%
	5	71.4	70				
	6	60.0	100				
	9	40.0	225				
	12	30.0	400				
GS - T	3	66.7	45	Abt. 0.20	75% Maximum	10% Minimum	150%
	5	40.0	125				
	6	33.3	180				
	9	22.2	405				
	12	16.7	720				
GS - L	3	50.0	60	Abt. 0.15	80%	10%	150%
	5	30.0	167				
	6	25.0	240				
	9	16.7	540				
	12	12.5	960				

## Ordering Information

GS - SH - 2 12 D

Coil Sensitivity:

D: 0.36W

T: 0.2W

L: 0.15W

Coil Voltage:

03: 3V, 05: 5V, 06: 6V, 09: 9V, 12: 12V, 24: 24V

Number of Pole:

2: Two Poles

Type of Sealing:

SH: RT III Wash Tight Relays

Type:

GS

## Classification

Model	GS		
Coil Sensitivity	Standard DC Coil	Middle Consumption DC Coil	High Sensitivity Type
Flow Solder Type	GS-SS-2□□D	GS-SS-2□□T	GS-SS-2□□L
Plastic Sealed Type	GS-SH-2□□D	GS-SH-2□□T	GS-SH-2□□L

Dimension ( $\leq 5\text{mm} \pm 0.2\text{mm}$ ,  $> 5\text{mm} \pm 0.3\text{mm}$ , the tolerance of PCB thru hole:  $+0.1\text{mm}$ )

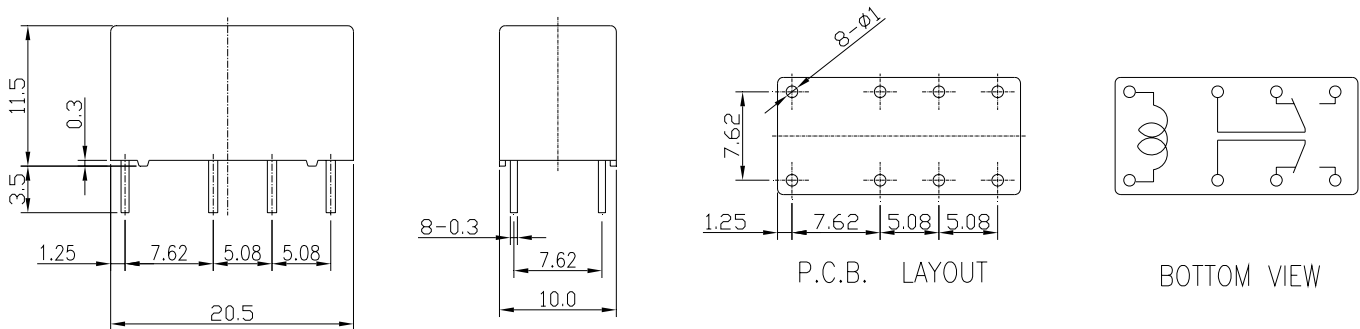

## Reference Data

