

Customer Information Sheet

DRAWING No.: S0941-46R

SHEET 2 OF 2

IF IN DOUBT - ASK

©

NOT TO SCALE

THIRD ANGLE PROJECTION

ALL DIMENSIONS IN mm

SPECIFICATION:
MATERIAL:
 CONTACT = STAINLESS STEEL, 0.15mm THICK
FINISH:
 1.0µm - 3.0µm TIN OVER 0.4µm - 1.5µm NICKEL
ELECTRICAL:
 RESISTANCE = 100mΩ MAX
MECHANICAL:
 INSERTION FORCE = 9.8N MAX
 WITHDRAWAL FORCE = 0.69N MIN
ENVIRONMENTAL:
 OPERATING TEMPERATURE = -40°C TO +85°C
 STORAGE TEMPERATURE = -40°C TO +85°C
SOLDERING DATA:
 SOLDERING HEAT RESISTANCE = 250°C FOR 5 SECONDS

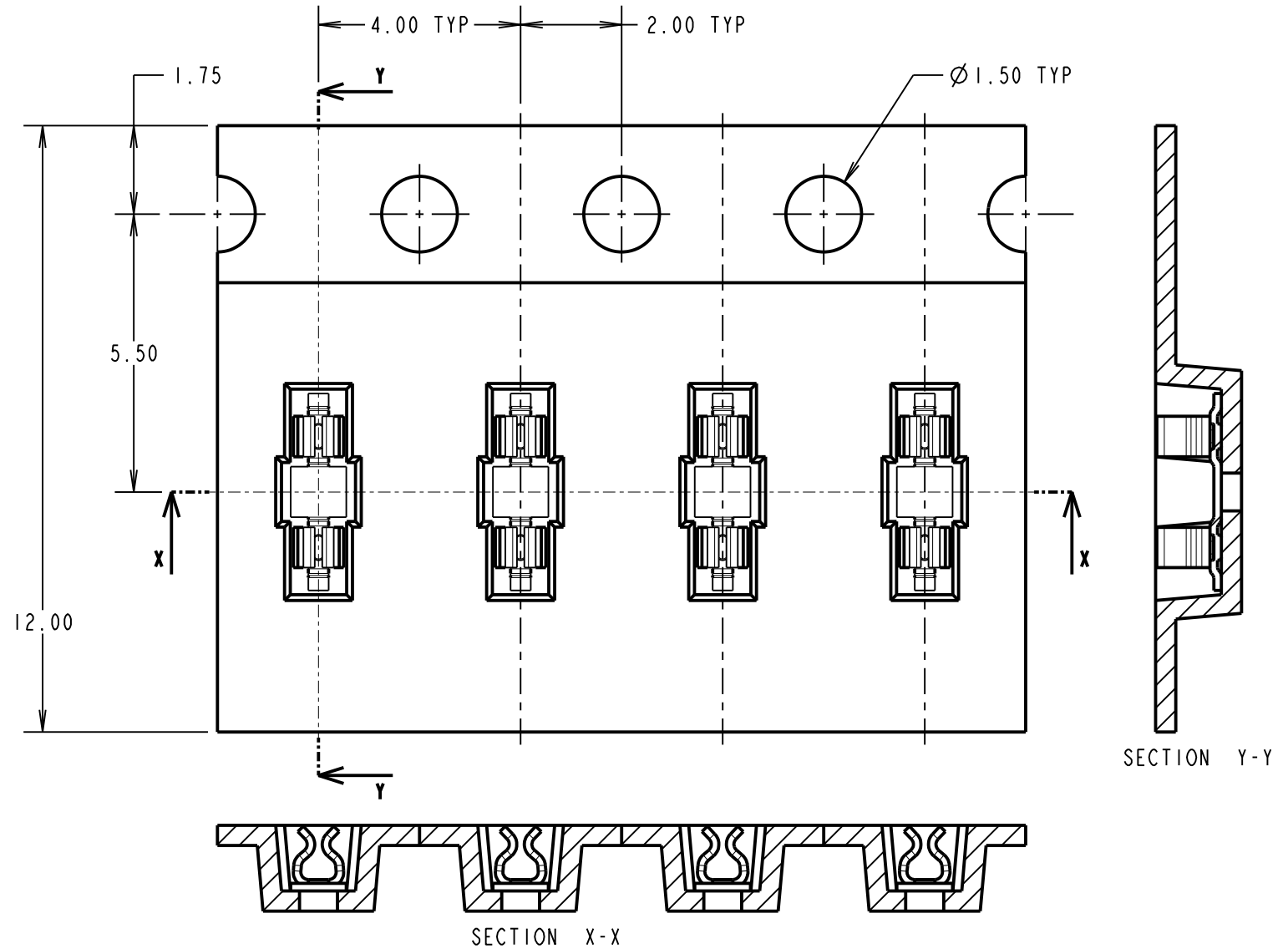
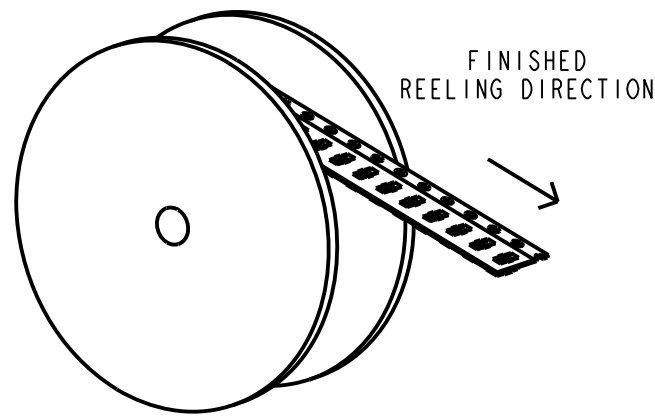

NOTES:
 1. FOR USE WITH 0.15 - 0.20mm THICK SHIELD CANS.
 2. QUANTITY PER REEL = 10,000.

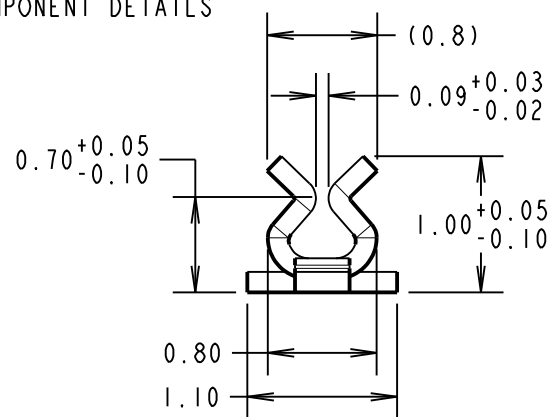
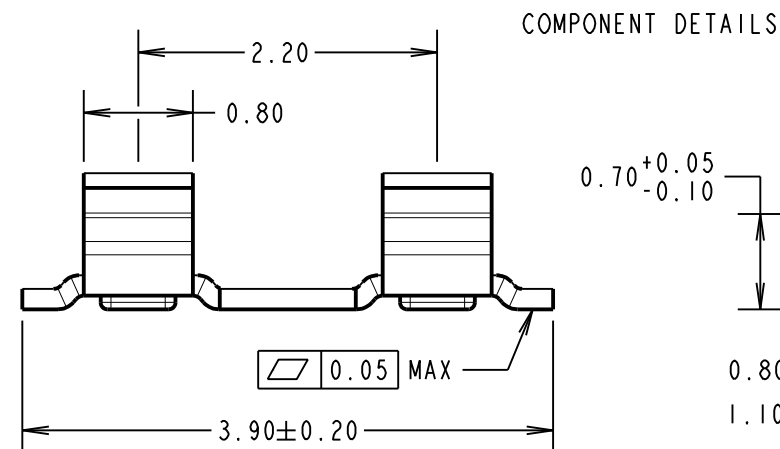
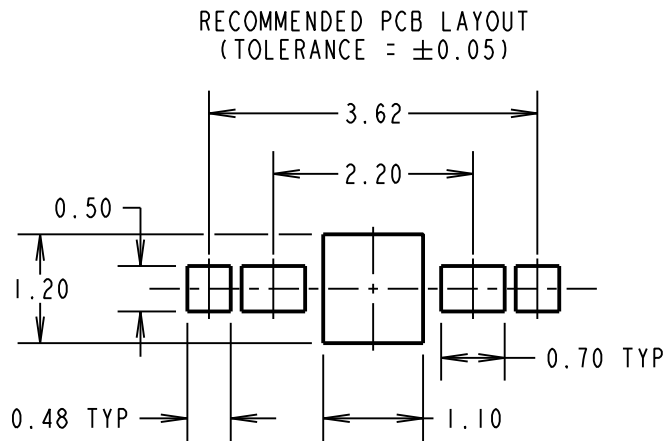
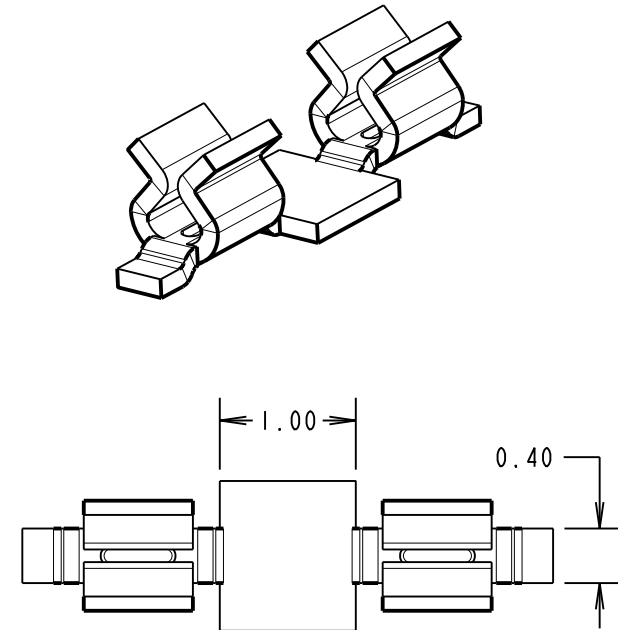

RECOMMENDED SHIELD CAN CUT OUT

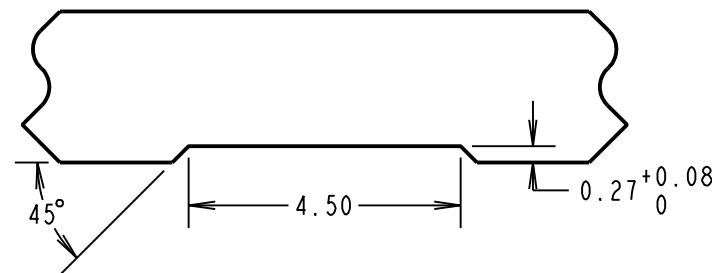

REEL DETAILS

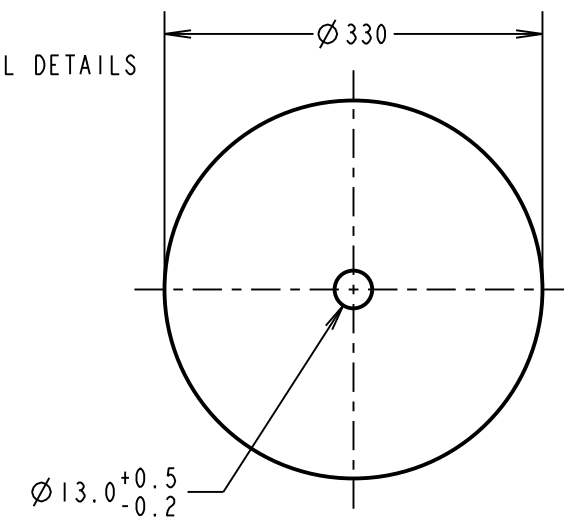

FM	3	18.12.17	20951
NAME	ISS.	DATE	C/NOTE
APPROVED: F. MCGOWAN			
CHECKED: M. PLESTED			
DRAWN: S. BENNETT			
CUSTOMER REF.:			
ASSEMBLY DRG:			

HARWIN

www.harwin.com
 technical@harwin.com

THIS DRAWING AND ANY INFORMATION OR DESCRIPTIVE MATTER SET OUT HEREON ARE CONFIDENTIAL AND COPYRIGHT PROPERTY OF THE HARWIN GROUP AND MUST NOT BE DISCLOSED, LOANED, COPIED OR USED FOR MANUFACTURING, TENDERING OR FOR ANY OTHER PURPOSE WITHOUT THEIR WRITTEN PERMISSION.

TOLERANCES
 X. = ±1mm
 X.X = ±0.50mm
 X.XX = ±0.10mm
 X.XXX = ±0.01mm
 ANGLES = ±5°
 UNLESS STATED

MATERIAL:
 SEE ABOVE
FINISH: SEE ABOVE
S/AREA: mm²

TITLE: SMT RFI SHIELD CLIP IN TAPE AND REEL

DRAWING NUMBER: S0941-46R

SHT 2 OF 2